

(No Model.)

G. F. BALLOU.

WORK CLAMP FOR SLIDE LATHES.

No. 359,376.

Patented Mar. 15, 1887.

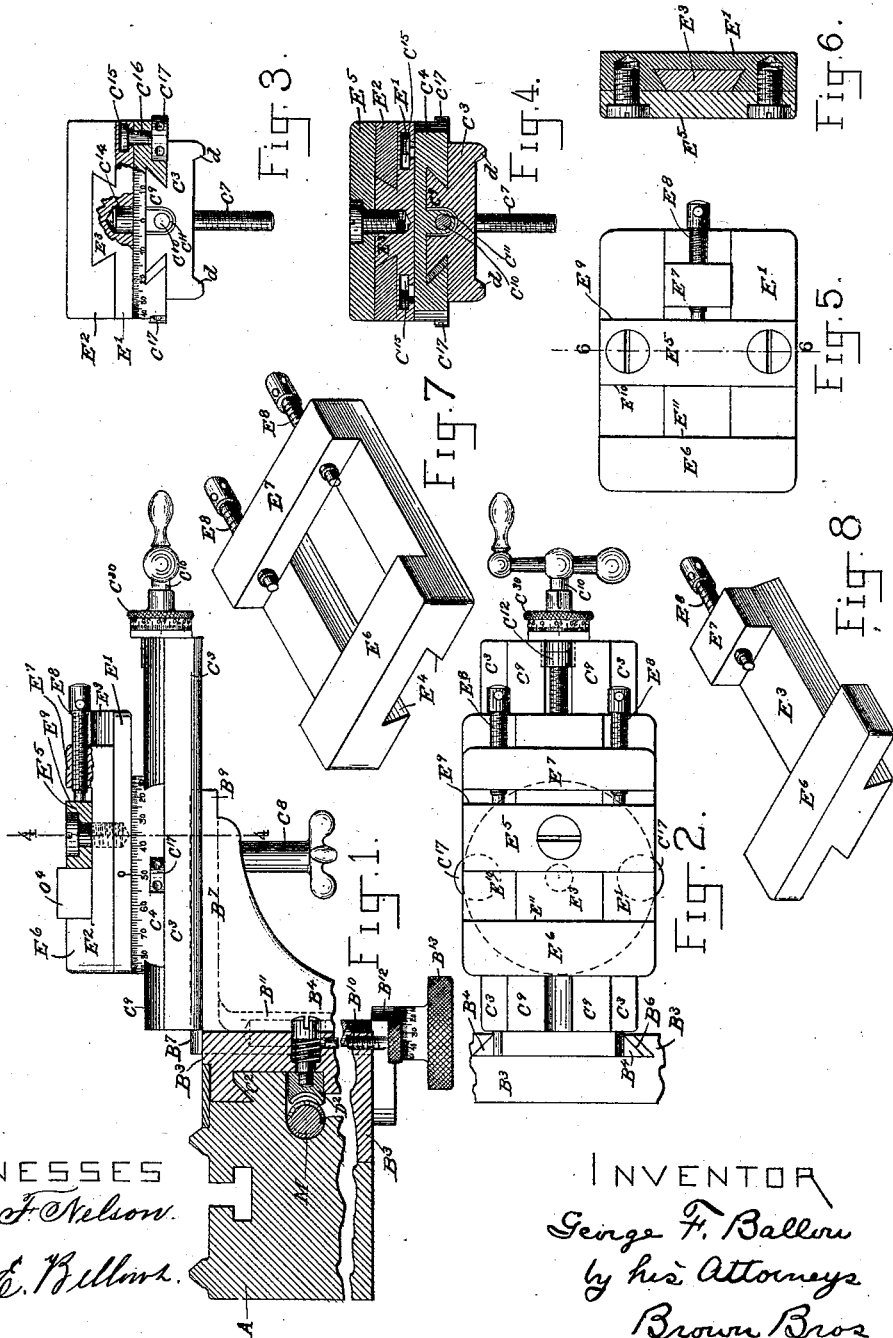

WITNESSES
John F. Nelson.
Kate C. Bellows.

INVENTOR
George F. Ballou
by his Attorneys
Brown Bros

UNITED STATES PATENT OFFICE.

GEORGE F. BALLOU, OF WALTHAM, MASSACHUSETTS.

WORK-CLAMP FOR SLIDE-LATHES.

SPECIFICATION forming part of Letters Patent No. 359,376, dated March 15, 1887.

Application filed June 9, 1886. Serial No. 204,620. (No model.)

To all whom it may concern:

Be it known that I, GEORGE F. BALLOU, of Waltham, in the county of Middlesex and State of Massachusetts, have invented certain new and useful Improvements in Work-Clamps for Slide-Lathes, of which the following is a full, clear, and exact description.

The work-clamp or vise of this invention is more particularly designed and intended for use in slide-lathes of the general construction and arrangement of parts, including the slide-rest and slide-carriage, fully shown and described in a separate application for Letters Patent of the United States of even date herewith, filed June 9, 1886, Serial No. 204,624; but, as will be obvious from the description hereinafter given, this clamp or vise is adapted to be used in slide-lathes and with slide-rests and slide-carriages of other constructions and arrangements of parts.

This invention, in substance, consists of a clamp or vise to be used in slide-lathes for clamping work in position to be operated upon therein—as, for instance, to be drilled, bored, milled, &c.—composed of two clamping-jaws, each carried by separate frames, constructed and arranged to be held together, and so held to be capable of a movement or slide rectilinearly upon each other and in a direction and manner thereby to adjust their clamping-faces in relation to each other and to the holding of work between them, in combination with a slide-rest of a slide-lathe made in separate parts, or slides constructed and applied together to be moved and adjusted upon each other in parallel and rectilinear planes and directions, and as a whole adapted to be secured to the lathe bed or shears, and, preferably, for adjustment longitudinally, vertically, and horizontally thereon, and having said clamp attached to one and the upper of its slides to be swung and adjusted thereon in a curvilinear direction and horizontal plane, and, so swung and adjusted, fastened against movement.

In the drawings forming a part of this specification the improved work-clamp or vise of this invention and its combination with the slide-rest and slide-carriage of a slide-lathe before referred to are illustrated.

Figure 1 is a transverse vertical section of the lathe-bed broken away, and a view in ele-

vation of the work-clamp or vise of this invention and of the slide-rest and slide-carriage from the head-stock end of the lathe, the head and tail stocks being removed. Fig. 2 is a plan view of the parts as shown, Fig. 1. Fig. 3 is a front end elevation of the work-clamp and slide-rest, with parts broken out and in vertical section. Fig. 4 is a vertical section on line 4 4, Fig. 1. Fig. 5 is a plan view illustrating a modification in construction of the work-clamp. Fig. 6 is a transverse section on line 6 6, Fig. 5. Figs. 7 and 8 are perspective views of one of the sliding frames of the work-clamp shown in the preceding figures, Fig. 7 relating to the work-clamp as it is shown in Figs. 1, 2, 3, and 4, and Fig. 8 as it is shown in Figs. 5 and 6.

In the drawings, A represents the lathe bed or shears of a slide-lathe. The slide-lathe in any and all respects, except as to the features of this invention hereinafter described, may be of any of the ordinary and well-known constructions and arrangements of slide-lathes; but a slide-lathe and a slide-carriage and a slide-rest therefor, all such as shown and described in the application stated, are most preferable, and which, so far as necessary for this invention, are shown and will be herein described, it not being thought necessary to fully illustrate the other parts thereof, as they in no particular form any part of the present invention.

M is the upper leading-screw of the slide-lathe referred to. The upper leading-screw, M, and also the lower leading-screw, (not shown,) are connected and rotated from the rotation of the lathe-arbor and otherwise, as described in said application. The rotation of the leading-screws is for the purpose of moving a slide-carriage lengthwise along the front cheek of the lathe bed or shears, and which carriage is suitably constructed therefor, and the upper leading-screw, M, which is for fine work, connects with horizontal sectional or half screw-nuts D² (one only shown, but two being preferable) of the slide-carriage, and the lower leading-screw, (not shown,) which is for general work, connects with the slide-carriage by mechanism consisting, among other parts, of a hand-wheel, (not shown,) and otherwise all as fully described and shown in the application aforesaid, and the whole such

as to enable the slide-carriage to be moved lengthwise of the lathe-bed in either direction, and either from the action of the driving mechanism of the lathe or by the hand-wheel, and also to enable the speed of such movement to be varied and adjusted and either of the leading-screws to be brought into action upon the slide-carriage, and all as is fully shown and set forth in the application aforesaid.

These several parts and their combination and arrangement, as above referred to, form of themselves no part of this invention, and so it is not deemed necessary to herein further describe them.

The slide-carriage is in two parts—to wit, a vertical plate or block, B², with a front flat face and a back face of angular shape to fit a corresponding angular-shaped guideway, C², thereof of the front cheek of the lathe-bed, and a bracket with an upright portion, B¹, arranged to move vertically in a dovetail way, B⁶, of the front face of the block B², and a horizontal arm, B⁷, which projects from the upper end of said upright B¹ and at right angles to the length of the slide-carriage, and is made of fork shape, and preferably with the space between its tines open at the front end, B⁹.

The bracket B¹ B⁷ is vertically adjustable on the slide-carriage through the turning of a vertical screw-rod, B¹⁰, engaging with the vertical screw-nut portion B¹¹ of the bracket, and turning loosely within a horizontal bearing-block, B¹², of the slide-carriage, and therein confined against lengthwise movement in any suitable manner. This screw-rod B¹⁰, by which to adjust the bracket B¹ B⁷ vertically, as above stated, has at its lower end a milled head, B¹³, peripherally and properly graduated in one hundred equal parts or divisions, each representing a one-thousandth of an inch, and figured for the rise and fall of the bracket from the turning of said screw to be measured and determined in one-thousandth parts of an inch, using a suitable index-mark at the front side of the bearing-block B¹² of the screw-rod.

The vertically-adjustable bracket B¹ B⁷ of slide-carriage supports and carries a slide-rest in two horizontal parts or slides, C³ and C⁴, placed upon each other. Slide C³—the lower slide of the two slides of the slide-rest—is made with flaring edges *d*, which fit and set over corresponding flaring edges of the bracket-table B⁷. The direction of these flaring edges transversely to the width of the bracket-table B⁷, and as shown, is preferably such as to permit slide C³ to be set bodily upon the bracket-table B⁷ without requiring it to be slid lengthwise along the same, and otherwise all arranged for slide C³, with all other parts connected therewith, to be moved horizontally on the table B⁷ forward to and backward from the axial line of the lathe-arbor. (Not shown.)

C⁴ is a screw-bolt projecting downward from slide C³ of slide-rest, and between the tines of the forked table B⁷ and C⁴ is a screw or thumb nut screwing on said bolt and fastening said

slide C³ to table B⁷ and against movement thereon. Slide C⁴ of the slide-rest fits by a dovetail way in its under side over a corresponding dovetail projection, C⁵, on the upper side of the lower slide, C³, and thus slides C³ C⁴ are adapted for a movement of the upper slide on the lower slide of the two, and in a horizontal plane, and one parallel with and in the direction of the horizontal slide of the lower slide, C³, on bracket B¹ B⁷. Slide C⁴ has a circular and vertical edge marked off or graduated in representation of the degrees of a circle, Fig. 1, and it is provided with a horizontal screw-rod, C¹⁰, which engages with a screw-nut, C¹¹, and turns loosely in a bearing-block, C¹², of the lower slide, C³, and by peripheral collar and groove (not shown) is engaged with bearing-block C¹², and this screw-rod C¹⁰, when turned, is confined against lengthwise movement through said block.

C¹⁰ is a milled head of screw C¹⁰. This head is peripherally graduated in one hundred equal parts, each using a suitably-located index-mark as a guide, representing, in the movement of the slide operated by the screw-rod, a one-thousandth part of an inch.

E¹ is one frame or slide, and E² the other frame or slide, of the clamp of this invention, for clamping work to be drilled or otherwise operated on in the lathe. The clamp-slide E¹ is the base-plate, as it were, of the clamp, and it contains the clamp-slide E², and the two are joined by a dovetail projection, E³, and way E⁴, so that they can be moved or slid lengthwise and in a right line upon each other.

As shown, Figs. 1, 2, 3, 4, and 7, the dovetail projection E³ is on the base-slide E¹, and dovetail way E⁴ on upper slide, E², and, Figs. 5 and 8, the dovetail projection is on upper slide, E², and the dovetail way on base-slide E¹, and in both instances such as to make close fit one with the other, and a fit suitable for the parts to be moved upon each other in the direction of their said dovetail projection and way.

The lower or base slide, E¹, of the clamp, and which receives the upper slide, E², as before stated, is provided with an attachable and detachable cross-piece, E⁵, making one jaw of the clamp. This jaw E⁵ crosses the upper face, and is located between two parallel cross-pieces, E⁶ E⁷, of the upper face of slide E², and the cross-piece E⁵ makes one and the remaining jaw of the clamp. The cross-piece E⁷ of slide E² has a set or thumb screw or screws, E⁸, screwed into it, and in a line parallel with the movement of clamp-slide E² on slide E¹, and suitable to make a bearing against edge E⁹ of the clamping-jaw E⁵ on slide E¹. Working the screws against the edge E⁹ of jaw E⁵ moves the slides E¹ E² of the clamp upon each other in opposite directions, to open and close the jaws E⁵ E⁶ as to their opposite parallel and clamping edges, E¹⁰ E¹¹, and thereby securing in the one case the unclamping from, and in the other case the clamping between,

said edges of a piece of work—such, for instance, as a block, O⁴, Fig. 1.

The lower or base slide, E', of the work-clamp sets upon the upper slide, C⁴, of the slide-rest, 5 and it is of a width corresponding to the diameter of the circular and graduated rim or edge of said slide. Again, slide E' of the clamp is arranged to swing around a vertical central pintle, C⁴, of rest-slide C⁴, and using 10 a suitable index-mark, Fig. 1, of its edge with the graduations of the circular edge of slide C⁴ the clamp can thus be adjusted definitely in a curvilinear direction and the work secured thereon placed in any angular direction 15 desired in relation to the rectilinear movements of the parts of the slide-rest on each other, and of the slide-rest, as a whole, on the slide-carriage and the slide-carriage with the slide-rest on the lathe-bed. The slide E' of 20 the work-clamp has a circular running groove, C¹⁵, of T shape in cross-section and concentric with the axis of swing of the clamp around the central pintle, C⁴, of slide-rest, and C¹⁶ are bolts at opposite diametrical points and 25 engaged by their T-shaped heads with said T-shaped grooves C¹⁵. These bolts C¹⁶ pass loosely through the thickness of slide C⁴, and on the under side of the slide each bolt receives a screw-nut, C¹⁷. Tightening the screw-nuts C¹⁷ fastens the clamp to, and loosening 30 them releases the clamp from, slide-rest, leaving it free to be swung around on the same.

In the practical use of the work-clamp, and with it attached to a slide-rest, as described, 35 the jaw E⁵ on slide E' is stationary, and the jaw E⁶ on slide E², under the action of the set or thumb screws E⁸, is moved forward and backward in relation thereto; and with a clamp of the construction and combination thereof 40 with a slide-rest and slide-carriage, all substantially as has been described, plainly the work secured in the clamp between the clamping-edges of its jaws can be presented to the tool of the lathe practically in any and all horizontal 45 directions and angles, each presentation being independent of the others.

The work-clamp herein described is most

particularly applicable to the slide-lathe, slide-rest, and slide-carriage herein referred to; but it is not to be limited thereto. 50

Again, the work-clamp of this invention is most serviceable as a means of holding work for being drilled, bored, milled, and otherwise operated upon in a slide-lathe, and it is particularly adapted for use with the vertical- 55 drilling fixture making the subject of separate application for Letters Patent of the United States of even date herewith.

Having thus described my invention, what I claim as my invention, and desire to secure 60 by Letters Patent, is—

1. In a slide-lathe, in combination, a clamp or vise to clamp work, composed of two clamping-jaws and separate frames, or slides for each jaw constructed and applied together to slide 65 one upon the other, and a slide-rest made in separate parts, or slides constructed and applied together to be moved and adjusted one upon the other in parallel and rectilinear planes and directions, and having said clamp 70 connected and secured thereto and arranged to swing thereon, substantially as described, for the purpose specified.

2. A clamp or vise for use in a slide-lathe to clamp work, composed of stationary and 75 moving clamping-jaws E⁵ E⁶, carried by separate frames or slides E' E², respectively, constructed with an engaging dovetail projection, E³, and way E⁴, and a cross-piece, E⁷, of slide E², having an adjusting screw or screws, E⁸, in 80 combination with a slide-rest composed of slides C³ and C⁴, rectilinearly adjustable one upon another, and having the said clamp arranged to swing about a central pintle, C⁴, of and to be secured to rest-slide C⁴, substantially 85 as described, for the purpose specified.

In testimony whereof I have hereunto set my hand in the presence of two subscribing witnesses.

GEO. F. BALLOU.

Witnesses:

ALBERT W. BROWN,
FRANCES M. BROWN.